

# MAPNET II/IDNet Communicating Devices, *Continued*

## 4090 MAPNET/IDNet ZAMs, *continued*

### Setting the Monitor ZAMs Address

Each Monitor ZAM has a unique address. The address of the ZAM is set via an eight-position dip switch, refer to the address chart (Figure 27) to set the ZAMs address.

### Mechanically Installing the Monitor ZAM

Install the Monitor ZAM into a grounded 4-inch U.L.-Listed back box (not supplied) using Figure 17 as a reference. Mount the ZAM to the back box as follows:

1. Loosen the two screws on the square back box.
2. Mount the ZAM to the back box using the teardrop holes on the mounting bracket.
3. Secure the ZAM to the back box using the two #8/32 panhead screws.

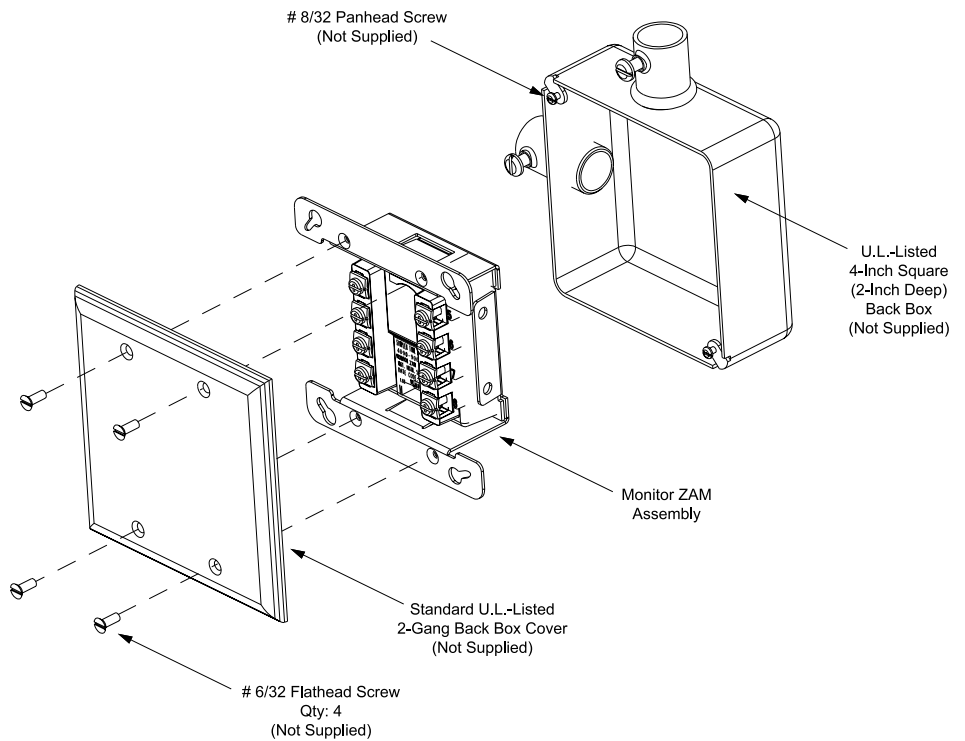

**Note:** Simplex offers semi-flush and surface covers (ordered separately) with a light pipe. The cover(s) with light pipe allow viewing of the communications LED without taking the cover off. Installation of the 4090-9801 semi-flush cover and 4090-9802 surface cover are detailed in publication *4090 IDNet™ Semi-Flush/Surface Covers and IAM Bracket Installation Instruction (574-796)*.

**Figure 17. Monitor ZAM Back Box Installation**

*Continued on next page*

# MAPNET II/IDNet Communicating Devices, *Continued*

## 4090-9001 Supervised IAM

### Introduction

The 4090-9001 is an individual addressable module (IAM) with both power and communications supplied by a two-wire MAPNET II or IDNet circuit. It provides location specific addressability to a single initiating device (such as single station smoke detector alarm contacts or heat detector contacts) or multiple devices at the same location by monitoring normally open dry contacts and the wiring to an end-of-line resistor.

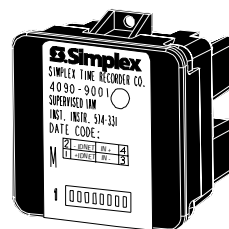

**Supervised IAM**

### IDNet

The 4090-9001 IAM provide four-state status information (NORMAL, OPEN, CURRENT-LIMITED, and SHORT) to the 4010 Fire Alarm Control Panel (FACP) via the IDNet channel. The IDNet channel provides the communication link between Supervised IAM and 4010 FACP and powers the entire IAM circuitry. A typical application for this module would be to monitor a waterflow switch.

### MAPNET II

The 4090-9001 Supervised IAM provides three-state status information (NORMAL, OPEN, and ALARM) to the host FACP via the MAPNET II channel. Applications that require current limit sensing are not compatible with MAPNET II channels (Tamper/Waterflow on the same IAM, Manual release/abort, etc.). The MAPNET II channel provides the communication link between the Supervised IAM and host 4100, or 4120, or 4020 FACP and powers the entire IAM circuitry.

### Making Electrical Connections to the Supervised IAM

**CAUTION: Do not loop wire under terminals. Break wire runs to provide supervision.**

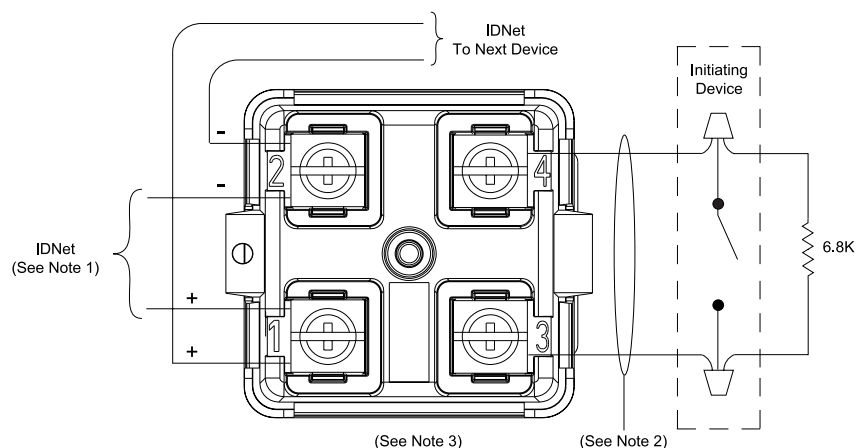

### Notes:

1. When connecting two wires to one terminal, position one wire on each side of the terminal screw.
2. IDNet and MAPNET II lines are 18 AWG twisted pair (shield recommended).
3. Maximum allowable run from FACP to farthest device not to exceed 2500 feet. Maximum total wire (including all T-Taps) from FACP is 10000 feet
4. Maximum wire length is 400 feet, #18 AWG.
5. Refer to Field Wiring Diagram 842-073 for further information on wiring Supervised IAMs to IDNet. Refer to Field Wiring Diagrams 841-804 or 841-996 for further information on wiring Supervised IAMs to MAPNET II. IDNet and MAPNET II wiring are supervised and Power-Limited.

**Figure 18. Supervised IAM Connections**

*Continued on next page*